

Pipe Welding Head

'F' Weld Head

The Liburdi Dimetrics Model F Head is designed for the automatic, in position GTAW (TIG) welding of pipes ranging from 2 inches to flat plate (and even ID curved surfaces). The F head is a remarkably versatile welding tool for any industry where high integrity welds are required, repetitively and quickly.

In its standard form, the F head provides a full function (with automatic Arc Voltage Control and Oscillation), cold wire configuration, with capability to adapt to both Hot Wire and Narrow Groove applications. It's versatile, high performance specification makes it ideally suited to run with the new and powerful Liburdi Dimetrics Gold Track VI power supply but can also be adapted to all previous Gold Track models.

With only a 4.7" (120mm) radial clearance, the F head indirectly mounts to pipes by means of an aluminium guide ring. A smooth and accurate weld head rotation is achieved

with the Liburdi Dimetrics patented backlash free friction drive mechanism.

All weld head function controls are conveniently located on the weld head side, providing an operator friendly alternative or in addition to the conventional remote pendant control. As with AVC, Oscillation and steering, wire manipulation is available in both vertical and horizontal adjustments and is accessible prior to and during the weld cycle.

All torch bodies are water-cooled and use commercially available standard torch consumables. The F-Head can accommodate the latest range of FireView direct vision systems.

A variety of wire feeder and spool holder configurations are available in including dual wire feed for bi-directional welding, to enhance the F Head's utility.



Weld Quality Starts in the Arc

USA | tel: 1-704-230-2510 | dimmktg@dimetrics.com
INTERNATIONAL | tel: 1-905-689-0734 | liburdi@liburdi.com
EUROPE | tel: +31-6-2036-1018 | liburdieurope@liburdi.com
www.liburdi.com



LIBURDI FIREVIEW COMPATIBLE

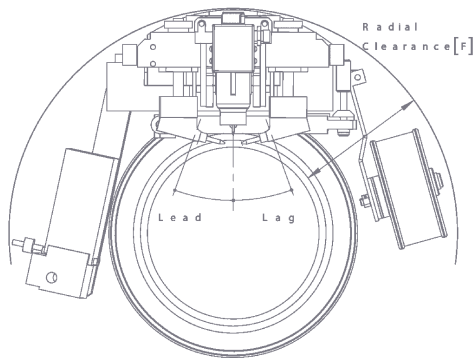
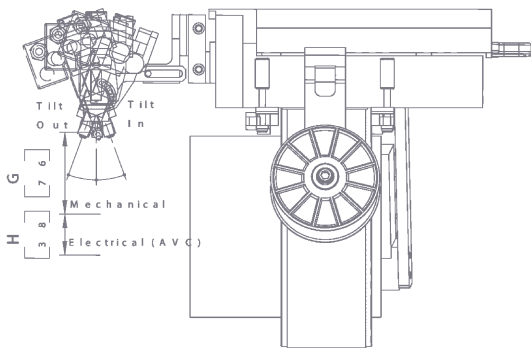
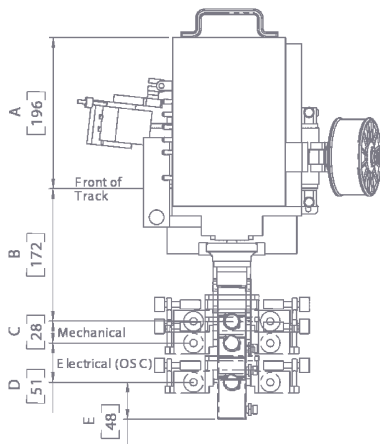

Liburdi Dimetrics GoldTrack® VI is a suitable power supply for the 'F' Weld Head System



Weld Quality Starts in the Arc

Standard Features

- Liquid Cooled Torch.
- AVC (Arc Voltage Control).
- Torch Oscillation .
- Electric Torch Center Steering.
- Jog Buttons conveniently located on the Weld Head.
- Can Weld in Forward and Reverse Directions.
- Suitable for Welding: Carbon Steel, Stainless Steel, Nickel Alloys, Copper-Nickel, Titanium, etc. and Aluminum Alloys when connected to the appropriate Power Source.
- Fully compatible with our "FireView" Vision System and portable viewing system in conjunction with our optional video front ends.

Specifications

- Available in Hot Wire Version
- Three Torch Models Available: "A" "C" and "Hot Wire Torch"
- Current Rating: 300 Amperes @ 100% (Model A and C Torches)
- Current Rating: 500 Amperes @ 100% (Hot Wire Torch)
- Maximum Travel Speed: 20 IPM (50 cm/min)
- Pipe Sizes from 2" (60mm O.D.) to Infinity
- Flat and Curved Surface Welding with "Straight Tracks" and "Flexible Tracks"
- Inside Welding with I.D. Adapter Kit from 16" (400mm) and up
- Wall Thickness: 0.125" - 6" (3-150mm) with appropriate accessories

Options

- Narrow Groove Torch
- Dual Wire Feeders (2x125 or 2x400 IPM)
- Dual Spool Holders (for 2x4" or 2x8" Spools)
- Dual Hot Wire Kit
- Socket Adapter Kit
- ID Adapter Kit (for Welding Inside a Pipe)
- Cable Modification Kit (for Welding Inside 16"Pipe)
- AVC - Oscillator Interchange Kit
- Extension Cables 50' (15m) (up to 6 extensions can be used depending on application)
- Video Front End for Remote Viewing
- Narrow Gap Video Front End

Physical Characteristics

For dimensions: see table below

Weight without cable: 20 lbs (9kg) depending on version

Cable length: 35' (11m)

*CE Compliant Version Available

DIMENSION	DESCRIPTION	A-Front End	C-Front End	Hot Wire
A	Track-to-Rear	7.725"(196mm)	7.725"(196mm)	7.725"(196mm)
B	Track-to-Electrode	5.600"(142mm)	6.769"(172mm)	6.769"(172mm)
Nominal	Track-to-Joint	6.625"(170mm)	8"(200mm)	8"(200mm)
C	Center Adjust	Electrical Only	1.120"(28mm)	1.120"(28mm)
D	Oscillator Stroke	2"(50mm)	2"(50mm)	2"(50mm)
E	Electrode-to-Front	0.884"(22mm)	1.886"(48mm)	1.625"(32mm)
F	Radial Clearance	4.688"(119mm)	4.688"(119mm)	6.490"(165mm)
G	Up/Down Adjust	1.5"(38mm)	3"(75mm)	3"(75mm)
H	AVC Stroke	1.5"(38mm)	1.5"(38mm)	1.5"(38mm)
Lead/Lag	Torch Adjust	15°/15°	15°/15°	15°/15°
Tilt	Torch Adjust	15°/15°	20°/20°	20°/20°
	Wire Feeder	120 IPM(3m/min)	120 IPM(3m/min)	400 IPM(10m/min)
	Spool Holder	4"(100mm)	4"(100mm)	8"(200mm)