

Gas Turbine Engineering Services

Independent Engineering and Analysis

The Liburdi Engineering Services offer:

- Metallurgical Analysis, Component Evaluation and Remaining Life Analysis
- Gas Turbine Performance and Detailed Design Analysis
- Remote Diagnostics and Performance Monitoring



Providing a diverse range of turbine services, metallurgical analysis, mechanical design, performance monitoring, repair development, and corporate research and development.

Our services in the turbine industry complement those offered by the original engine manufacturers while providing the added benefit of an independent engineering analysis and advanced, life extending, refurbishment processes and coatings.

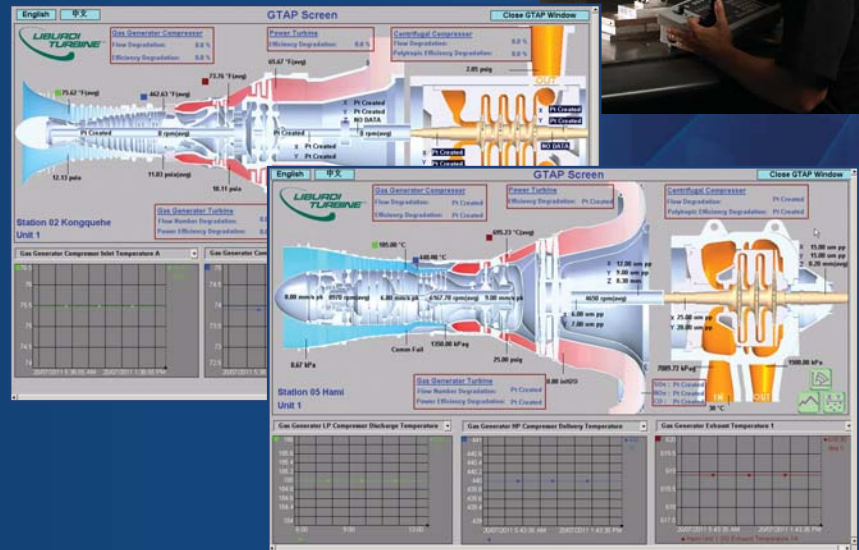

Independent Component Failure Analysis and Modifications / Upgrades

- Metallurgical analysis to determine nature, extent, and cause of component damage – this enables appropriate repair and upgrades to be developed to prevent or mitigate future damage
- Experienced in engine and component design Aerodynamics and Performance Analysis
- Assessment of suitability of design, including modifications and redesigns if needed
- Development of advanced repair and coating technologies
- Expertise using industry proven design and analytical tools

Field Proven – Liburdi's Turbine Engine Performance Analysis Software

- Turbine Stage-by-Stage analysis, used in evaluating engine performance over full operating range
- **WebGTAP™ Gas Turbine Analysis Performance Software** – detailed engine performance model to identify power and efficiency degradations vs baseline performance - used by engine manufacturers and packagers as well as fleet operators to analyse and predict on-site performance
- **LGTP™ - Gas Turbine Health Monitoring** with access to control room data inputs, enabling on-site performance analysis and optimization
- **CEHM™ Engine Lifting and Overhaul Assessment** – maximizing output and extending maintenance intervals through application of a unique metallurgical model for true On-Condition Maintenance of individual engines.

Turbine Component Remaining Life Analysis

Metallurgical examination of hot gas path components assessed for remaining service life includes characterizing the type of damage and quantifying the extent of material degradation so that an informed and cost effective repair, replacement, or upgrade decision can be made.

Component Life Analysis (Blades, Vanes, Combustors, etc.)

- Analysis can include investigation of:
 - damage mechanisms and source of damage
 - oxidation/corrosion attack
 - coating remaining life and integrity
 - alloy microstructural degradation
 - reduced creep strength
 - critical dimensional changes
 - effects of operating duty cycle, fuel quality, water/steam injection, airborne contaminants

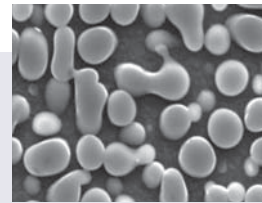

10,000x magnification – service aged alloy microstructure

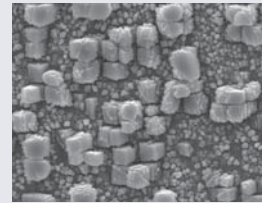

10,000x magnification – as-new alloy microstructure

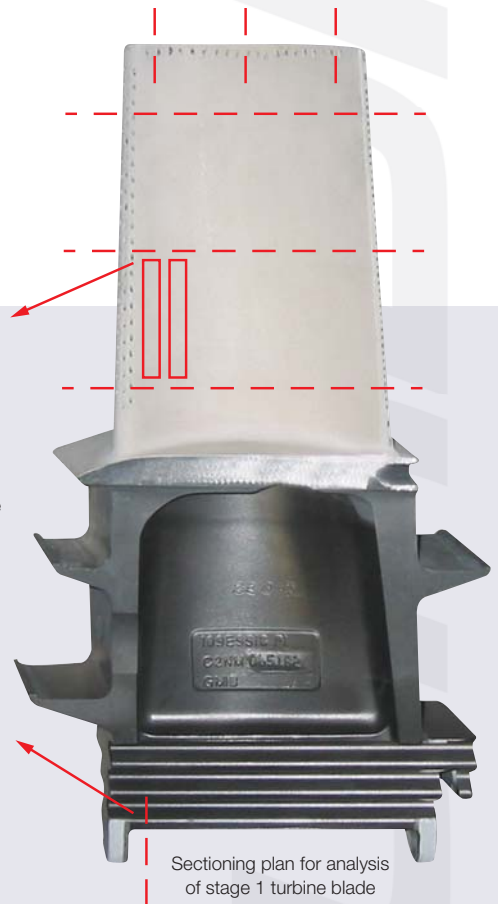

Disc Life Trend Analysis

- Liburdi's proven methodology in modeling the complete blade/disc assembly and implementation of modern Finite Element Stress Analysis
- Determine metal temperature profile
- Determines stress concentrations, applies stress relaxation algorithms, and ultimately determines the service life expectancy of the disc for the intended service
- Results of the engineering analysis can be applied to the operator's entire fleet

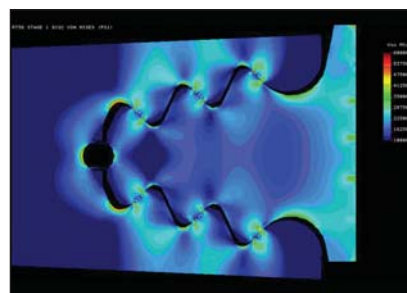
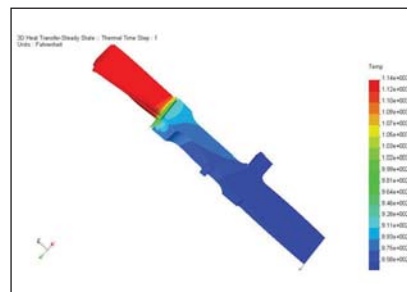

Independent Perspective – Industry Leading Technologies

Liburdi Turbine Services

International Canada

tel: 1-905-689-0734
fax: 1-905-689-0739
email: liburdi@liburdi.com

USA

tel: 1-704-230-2510
fax: 1-704-230-2555
email: liburdi@liburdi.com

Liburdi Asia

Shanghai, China

OLTS Liburdi

St. Petersburg, Russia