

# MSIV Repair Tool

Liburdi Dimetrics® Automated Welding Systems



- Interchangeable Process Head
- Co-ordinated Motion
- Laser CMM for Precise Measurement
- FireView™ Control Console

## **Reduce your setup and total repair time with the MSIV Repair Tool.**

Liburdi Dimetrics® provides a fully automated “Main Steam Isolation Valve” (MSIV) Repair Tool solution specifically for the power gen industry. The only of its kind, the MSIV contains interchangeable process heads, Liburdi Dimetrics® GoldTrack VI™ power supply and Liburdi’s advanced FireView™ control technology; providing motion while inspecting, welding, machining, milling, and grinding repair areas.

This unique system is capable of performing all tasks necessary to refurbish a MSIV in a single setup. A common cage and plug assembly secures the robust boring bar for the tool post to travel axially.

Once installed and aligned, the MSIV Repair Tool remains in a fixed position until the repair process is completed. The Fireview™ Control Console provides programming flexibility by allowing multiple screen configurations, specifically designed for each MSIV repair operation.

The MSIV Repair Tool incorporates six different operations:

- Laser CMM Inspection
- Milling
- GTAW Cladding
- Single Point Machining
- Grinding
- Lapping



USA | tel: 1-704-230-2510 | [dimmktg@dimetrics.com](mailto:dimmktg@dimetrics.com)  
INTERNATIONAL | tel: 1-905-689-0734 | [liburdi@liburdi.com](mailto:liburdi@liburdi.com)  
EUROPE | tel: +31-6-2036-1018 | [liburdieurope@liburdi.com](mailto:liburdieurope@liburdi.com)  
[www.liburdi.com](http://www.liburdi.com)

# MSIV Repair Tool

Liburdi Dimetrics® Automated Welding Systems

## Local Station and Remote Station Assemblies

### Local Station:

#### GTVI:

- Up to 600 amps GTAW
- Up to 12 servos
- Ethernet connection with FireView™ Cabinet
- Water cooler and gas controls
- 85 ft long pendant cable
- Additional specs: Refer to GTVI data sheet

#### FireView™ Control Console:

- Industrial PC with touch screen control interface
- Smart servo drives with position feedback
- Analog and digital camera capability
- Laser CMM controller
- Input power: 3 phases 480 V 50/60 Hz



### Remote Station:

#### Features and dimensions for MSIV repair:

- Multiple slip rings to allow continuous rotation of machine heads
- Secondary industrial touch screen controller
- Quick disconnect hot block for simplified setup

#### Cage Assembly:

- Mounts on the flange of the MSIV
- Adjustable cage bearing assembly

#### Boring Bar Assembly:

- Secured between Cage Assembly and Plug Assembly
- Hardened, precision ground chrome plated boring bar
- Tool post featuring a unique one bolt locking mechanism that is used to secure all tooling attachments
- Various tool travel ranges available

#### Plug Assembly:

- Secured in place with adjustable supports, so that allowances can be made for casting variations
- Adjustable plug bearing assembly

MSIV Repair Tool Configuration

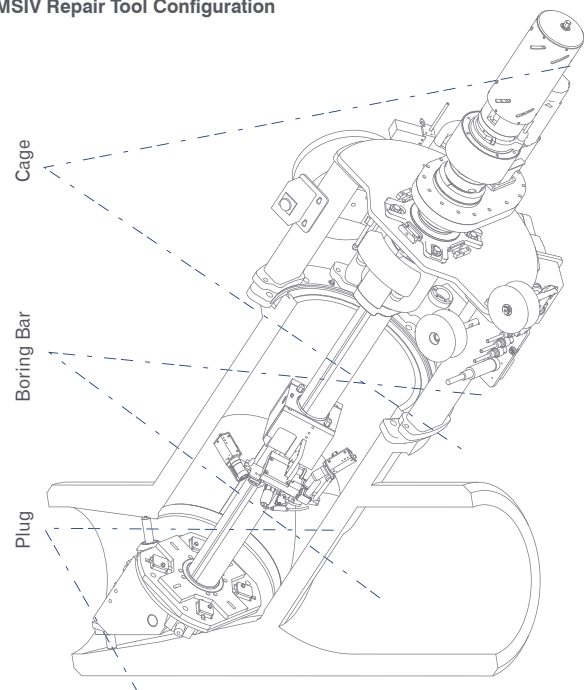

USA | tel: 1-704-230-2510 | [dimmktg@dimetrics.com](mailto:dimmktg@dimetrics.com)  
INTERNATIONAL | tel: 1-905-689-0734 | [liburdi@liburdi.com](mailto:liburdi@liburdi.com)  
EUROPE | tel: +31-6-2036-1018 | [liburdieurope@liburdi.com](mailto:liburdieurope@liburdi.com)  
[www.liburdi.com](http://www.liburdi.com)





Flange Inspection

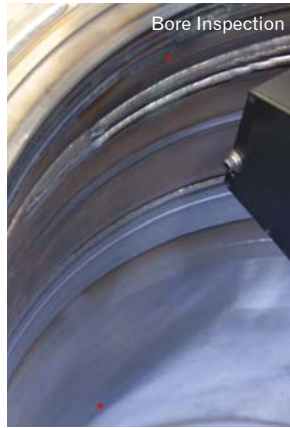

Bore Inspection

### Inspection Head

#### Features:

- Non-contact laser displacement sensors
- Complete dimensional data report for the valve profile
- Reports include five operations:
  - Tooling alignment setup
  - Flange
  - Valve bore
  - Bore guide rib
  - Bore guide pad
- All surfaces are measured, recorded, and charted, thus providing a true valve dimensional history.

#### Specifications:

- Resolution: Measurement Sensor  $\pm 0.0001$ "
- Z Axis  $\pm 0.0005$ "
- Theta Axis  $\pm 0.01^\circ$

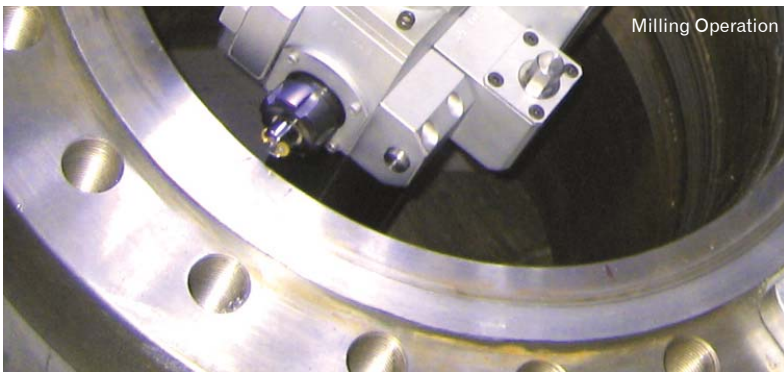

Milling Operation

### Milling Head

#### Features:

- Used for local repair on internal valve body
- Primarily used to remove material for weld preparation on the guide pads and guide ribs
- Consists of a driven collet chuck equipped with an indexable endmill
- Brushless motor with encoder
- Vision camera with external LED lighting
- Linear gauge with remote digital readout

#### Specifications:

- Resolution: Manual Plunge  $\pm 0.0005$ "
- Z Axis  $\pm 0.0005$ "
- Theta Axis  $\pm 0.01^\circ$



Flange



Bore



Guide Rib

### Weld Head

#### Features:

- Easily configurable weld head for cladding multiple locations: flange, valve bore, guide rib, guide pad, and seat bore
- Standard GTAW machine torch
- Multiple high resolution cameras with automatic weld lens selection
- Four servos control: AVC, X-Y wire positioners, and wire feeder
- Suitable for carbon steel and hard face alloys

#### Specifications:

- Current Rating: 300 Amperes @ 100%
- AVC (Arc Voltage Control): 1.5" travel
- Wire Feeder accepts  $\varnothing.030$ " to  $\varnothing.063$ "



# MSIV Repair Tool

Liburdi Dimetrics® Automated Welding Systems

## Machine Heads

### Features:

- Designed to cover all machining requirements on flange, bore, guide rib, guide pad, and seat bore.
- Dual head system allowing two simultaneously cuts
- Motorized tool cutter (R Axis)
- Vision camera with external LED lighting
- Home position limit switch

### Specifications:

- Resolution: R Axis  $\pm 0.0005''$   
Z Axis  $\pm 0.0005''$   
Theta Axis  $\pm 0.01^\circ$

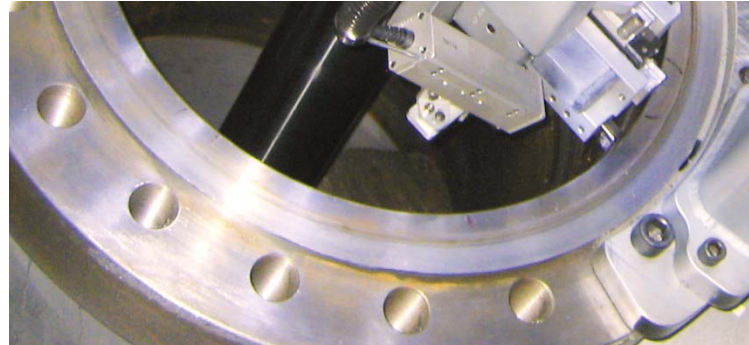

## Grinding Head

### Features:

- Grinding head is used to establish a true and good surface on the valve seat.

### Specifications:

- Maximum 3" grinding wheel diameter.

## Lapping Heads

### Features:

- Extendable lapping head is used for final polishing of the valve seat to desired micro-finish.
- Vision camera with LED light

### Specifications:

- Seat angle:  $45^\circ$

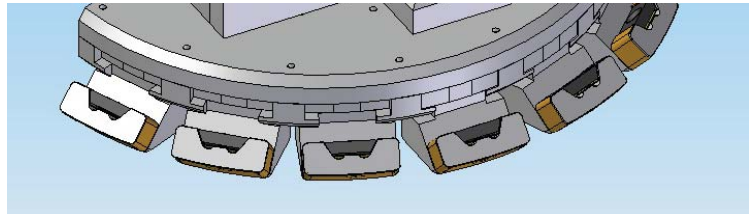

## Fireview™ User Interface

- Application specific control interfaces
- Automatic and manual control
- Linkable programs and program library
- Data Logging
- MPEG-4 video recording and playback
- Dual selectable camera views
- Simultaneously collects and displays acquired valve profile data
- Automatic Excel report and graph generation
- Automatic weld lens selection
- AVC and wire feed control
- Motorized wire position control
- Coordinated motion for advanced cuts



© Liburdi Dimetrics Corp. February 17, 2012. Specs subject to change



USA | tel: 1-704-230-2510 | [dimmktg@dimetrics.com](mailto:dimmktg@dimetrics.com)  
INTERNATIONAL | tel: 1-905-689-0734 | [liburdi@liburdi.com](mailto:liburdi@liburdi.com)  
EUROPE | tel: +31-6-2036-1018 | [liburdieurope@liburdi.com](mailto:liburdieurope@liburdi.com)  
[www.liburdi.com](http://www.liburdi.com)