



Miniature Tube and Fitting Applications

DMF-A 1

The DMF-A1 Weld Head fulfils the requirements of small diameter tube welding from 1/8" to 1/2" OD within the Semiconductor and Aerospace industries. With a 0.250" axial clearance, the A1 is designed for mini-fitting welding in cleanroom and/or high productivity welding applications. Whether in position or on a welding bench, both UHP and custom welding applications can benefit from the simplicity and effectiveness of the Liburdi Dimetrics orbital package.



Weld Quality Starts in the Arc

USA | tel: 1-704-230-2510 | dimmktg@dimetrics.com
INTERNATIONAL | tel: 1-905-689-0734 | liburdi@liburdi.com
EUROPE | tel: +31-6-2036-1018 | liburdieurope@liburdi.com
www.liburdi.com

Standard Features

Interchangeable, precision tube clamp assemblies accept tube and fitting diameters ranging from 1/8" (3.2mm) to 1/2" (12.7mm).

The narrow profile requires only 0.236" (6.0mm) clearance from the tungsten to the weld joint.

Accommodates tube-to-tube, tube-to-fitting and fitting-to-fitting applications.

START, STOP and JOG controls build into the handle for convenience, ease of operator use and greater system flexibility.

Directly interfaces to all Liburdi Dimetrics tube welding power supplies.

Can be adapted for use on a variety of manufacturers' power supplies.

An optional 30 RPM motor configuration allows for greater welding speed on appropriate applications.

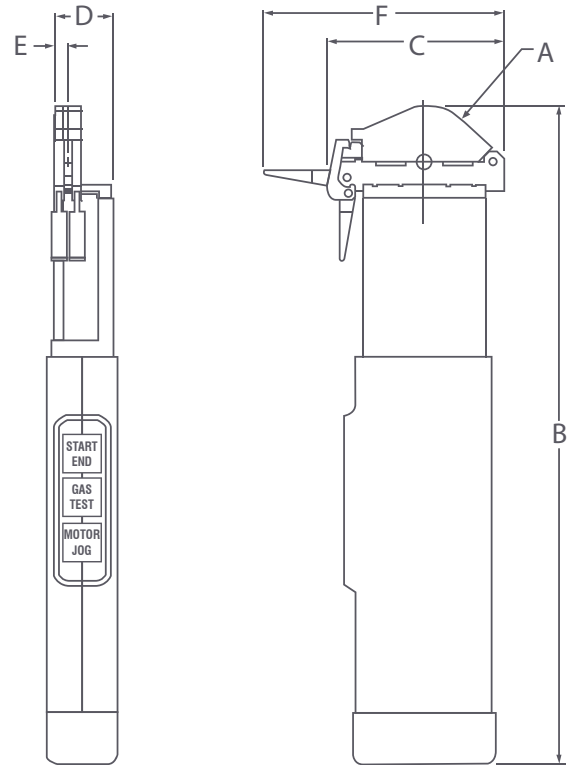

Model Number

A1

- Tube Diameter Range: Micro-Fittings
- Pipe Size Range: N/A
- Maximum RPM: 10.0
- Weight (excl. cable):

Dimensions

- "A" Radius: .98"
- "B" Length: 9.80"
- "C" Width: 3.08"
- "D" Thickness: 1.018"
- "E" Tungsten Centerline: .235"
- "E" Minimum Offset Centerline: .250"

Axis

Rotor Speed: 0.1 through 10 RPM standard
0.1 through 30 RPM optional

Standard Configuration

- Electrode: 0.040" or 0.062" (Ø1.0 or 1.6mm)
- Tungsten Offset: 0.250" (6.35mm) for standard fittings
0.236" (6.0mm) for special fittings
- Tube Size: 1/8" O.D. (3.2mm) through 1/2" O.D. (12.7mm) tubing
- Remote Controls: Start/Stop/Jog
- Clamp Assemblies: Available in standard or "split" clamp configurations

Physical Characteristics

- Physical Dimensions: 9.63" (245mm) long from top of clam to base of handle
3.077" (80mm) at widest part of clamp
0.47" (12mm) total width of clamp
- Cable Length: 25' (7.5m) standard



Weld Quality Starts in the Arc

USA | tel: 1-704-230-2510 | dimmktg@dimetrics.com
INTERNATIONAL | tel: 1-905-689-0734 | liburdi@liburdi.com
EUROPE | tel: +31-6-2036-1018 | liburdieurope@liburdi.com
www.liburdi.com



'Liburdi Dimetrics' PTW160c™ is an excellent power supply for the DMF-A1 Weld Head.